**Carbon-fibre-reinforced plastics —
Determination of compression-after-
impact properties at a specified
impact-energy level**

*Plastiques renforcés de fibres de carbone — Détermination des
propriétés de compression après impact à un niveau d'énergie spécifié*



PDF disclaimer

This PDF file may contain embedded typefaces. In accordance with Adobe's licensing policy, this file may be printed or viewed but shall not be edited unless the typefaces which are embedded are licensed to and installed on the computer performing the editing. In downloading this file, parties accept therein the responsibility of not infringing Adobe's licensing policy. The ISO Central Secretariat accepts no liability in this area.

Adobe is a trademark of Adobe Systems Incorporated.

Details of the software products used to create this PDF file can be found in the General Info relative to the file; the PDF-creation parameters were optimized for printing. Every care has been taken to ensure that the file is suitable for use by ISO member bodies. In the unlikely event that a problem relating to it is found, please inform the Central Secretariat at the address given below.

常州合成材料研究院有限公司
内部收藏



COPYRIGHT PROTECTED DOCUMENT

© ISO 2009

All rights reserved. Unless otherwise specified, no part of this publication may be reproduced or utilized in any form or by any means, electronic or mechanical, including photocopying and microfilm, without permission in writing from either ISO at the address below or ISO's member body in the country of the requester.

ISO copyright office
Case postale 56 • CH-1211 Geneva 20
Tel. + 41 22 749 01 11
Fax + 41 22 749 09 47
E-mail copyright@iso.org
Web www.iso.org

Published in Switzerland

Contents

Page

Foreword.....	iv
1 Scope	1
2 Normative references	1
3 Terms and definitions.....	2
4 Principle.....	3
5 Conditioning of specimens and test environment.....	4
5.1 Standard conditioning procedure for specimens	4
5.2 Environmental test chamber for impact and compression tests	4
6 Test apparatus	4
6.1 General.....	4
6.2 Impact facility	4
6.3 Support fixture for specimen.....	4
6.4 Non-destructive testing instrument.....	6
6.5 Compression-testing machine	6
6.6 Compression-loading fixture.....	6
6.7 Measuring apparatus.....	7
6.8 Strain gauges	8
7 Specimens	8
7.1 Dimensions.....	8
7.2 Specimen preparation	9
7.3 Number of specimens	10
8 Procedure	10
8.1 Specimen conditioning	10
8.2 Measurement of specimen dimensions.....	10
8.3 Impact test.....	10
8.4 Non-destructive testing (NDT).....	11
8.5 Inspection of specimens	11
8.6 Compression test.....	11
9 Validation.....	13
10 Calculation of results	14
10.1 CAI strength	14
10.2 CAI modulus.....	15
10.3 Maximum CAI strain	15
10.4 Rounding the results.....	15
10.5 Standard deviation and coefficient of variation	15
11 Test report	16
Annex A (normative) Detailed drawings of the components of the compression-loading fixture	17
Bibliography	20

Foreword

ISO (the International Organization for Standardization) is a worldwide federation of national standards bodies (ISO member bodies). The work of preparing International Standards is normally carried out through ISO technical committees. Each member body interested in a subject for which a technical committee has been established has the right to be represented on that committee. International organizations, governmental and non-governmental, in liaison with ISO, also take part in the work. ISO collaborates closely with the International Electrotechnical Commission (IEC) on all matters of electrotechnical standardization.

International Standards are drafted in accordance with the rules given in the ISO/IEC Directives, Part 2.

The main task of technical committees is to prepare International Standards. Draft International Standards adopted by the technical committees are circulated to the member bodies for voting. Publication as an International Standard requires approval by at least 75 % of the member bodies casting a vote.

Attention is drawn to the possibility that some of the elements of this document may be the subject of patent rights. ISO shall not be held responsible for identifying any or all such patent rights.

ISO 18352 was prepared by Technical Committee ISO/TC 61, *Plastics*, Subcommittee SC 13, *Composites and reinforcement fibres*.

内部收藏
材料研究院有限公司

Carbon-fibre-reinforced plastics — Determination of compression-after-impact properties at a specified impact-energy level

1 Scope

This International Standard specifies a method for determining the residual compression strength of multidirectional polymer matrix composite laminate plates that have been damaged by impact prior to the application of in-plane compressive loading.

The test method is suitable for continuous-fibre-reinforced polymer matrix composites. Application of the method is limited to fibre-reinforced plastic laminates with multidirectional reinforcements manufactured from unidirectional prepreg tapes/fabrics or woven fabrics.

The test method is referred to as the compression-after-impact (CAI) test when used to determine the residual compression strength of an impacted plate. It can be used to obtain data for material specification, material evaluation, research and development, or construction of a composite database.

2 Normative references

The following referenced documents are indispensable for the application of this document. For dated references, only the edition cited applies. For undated references, the latest edition of the referenced document (including any amendments) applies.

ISO 291, *Plastics — Standard atmospheres for conditioning and testing*

ISO 1268-4:2005, *Fibre-reinforced plastics — Methods of producing test plates — Part 4: Moulding of prepregs*

ISO 5893, *Rubber and plastics test equipment — Tensile, flexural and compression types (constant rate of traverse) — Specification*

ISO 14127, *Carbon-fibre-reinforced composites — Determination of the resin, fibre and void contents*

ISO 80000-1:—¹⁾, *Quantities and units — Part 1: General*

1) To be published. (Revision of ISO 31-0:1992)

3 Terms and definitions

For the purposes of this document, the following terms and definitions apply.

- 3.1**
compression-after-impact test
CAI test
in-plane compression test undertaken on a composite laminate loaded in the plane of the laminate, after applying an out-of-plane concentrated impact load under defined conditions
- 3.2**
specified impact energy
potential energy of the drop-weight, specified by the mass and drop height of the indenter, to which composite laminate specimens will be subjected, expressed in joules
- 3.3**
barely visible impact damage
BVID
impact damage corresponding to a dent depth of 0,3 mm
- 3.4**
energy to cause BVID
 E_{BVID}
impact energy required to cause BVID, expressed in joules
- 3.5**
compression-after-impact strength
 σ_{CAI}
maximum compressive load sustained by the impacted specimen divided by the initial cross-sectional area of the specimen, expressed in MN/m²
- 3.6**
compression-after-impact modulus
 E_{CAI}
compression modulus of the specimen calculated between 0,05 % and 0,25 % strain, expressed in GN/m²
- 3.7**
maximum compressive strain
 $\varepsilon_{\text{cmax}}$
maximum value of the compressive strain sustained by the specimen at the maximum compressive load
- 3.8**
dent depth
residual depth of the depression formed by the indenter after the impact event, expressed as the maximum distance, in millimetres, in a direction normal to the face of the specimen from the lowest point in the dent to the plane of the undisturbed impact surface
- 3.9**
damage parameters
quantities used to characterize the extent of impact damage, including the maximum diameter of the delamination and the projected area of the delamination

4 Principle

The CAI test detailed in this International Standard consists of three phases as depicted in Figure 1.

The first phase is to generate barely visible impact damage (BVID), avoiding penetration of the test plate. The preferred method of introducing BVID is based on a specified level of impact energy applied to one face of a specimen made of a balanced and symmetrical composite laminate.

NOTE An alternative method allows the operator to vary the level of impact energy in order to determine the energy level required to cause BVID. An additional ISO method will be proposed and drafted to cover this method of setting the impact energy.

The second phase consists of assessing the level of impact damage by non-destructive testing (NDT) [also referred to as non-destructive inspection (NDI)] and by measurement of the dent depth on the impacted face. The area and geometry of the damage created by the impact shall be measured by means of an appropriate non-destructive testing technique, and the dent depth measured by a suitable device.

Measurement of residual in-plane compression properties is undertaken in the third stage. A compressive load is applied to the impacted specimen until failure occurs. The CAI strength, modulus and strain are calculated from the load strain data collected, as detailed in Clause 10.

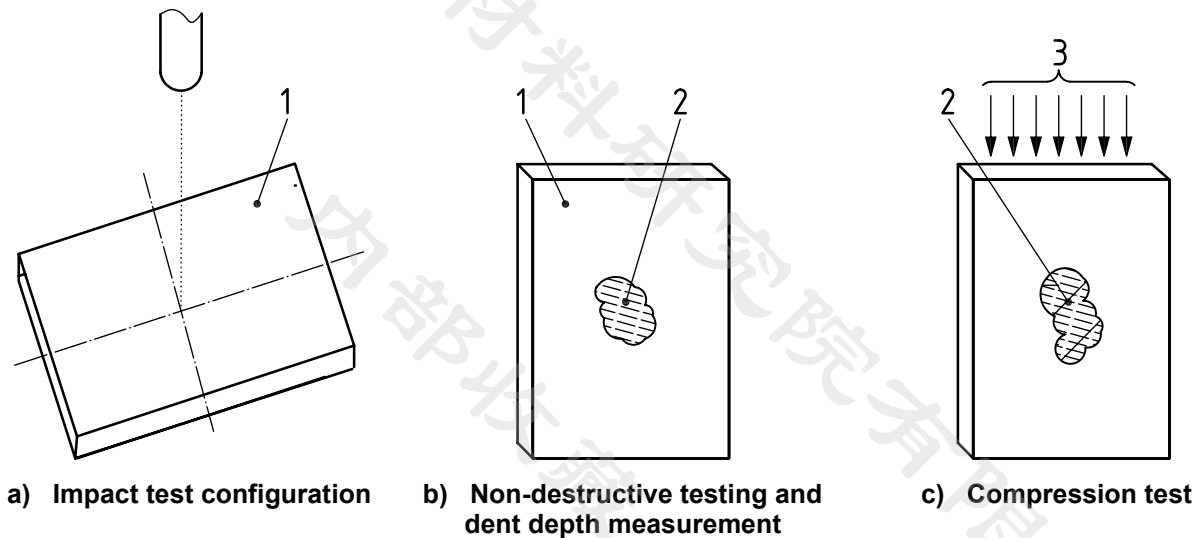

Key

- 1 specimen
- 2 delamination
- 3 compressive load, F

Figure 1 — Principle of the compression-after-impact test

A flat, rectangular composite plate is subjected to a transverse, concentrated impact using a drop-weight device with a hemispherical indenter. The energy of the impact, determined by the mass and drop height of the indenter, is specified. Equipment and procedures are prescribed for measurement of the contact force and the indenter velocity during the impact event. Damage resistance is quantified in terms of the extent and type of damage present in the specimen after impact.

After impact, an in-plane compressive load is applied to the specimen until failure, and the compression-after-impact strength, modulus and strain are calculated from the recorded load-strain response.

The properties measured by this test method are highly dependent upon several factors, including specimen geometry, laminate lay-up, indenter geometry, indenter mass, impact energy, impact force, damage size and location and support conditions. Thus, the results are generally not comparable to other CAI test configurations but are particular to the specific combination of geometric and physical test parameters used.

The test does not provide information to satisfy structural-integrity and safety requirements. It is the responsibility of the user to consider and establish appropriate structural-integrity limits and safety factors.

5 Conditioning of specimens and test environment

5.1 Standard conditioning procedure for specimens

Specimens shall be conditioned at (23 ± 2) °C and (50 ± 10) % RH unless different conditions are agreed upon by the interested parties.

5.2 Environmental test chamber for impact and compression tests

An environmental test chamber is required for test environments other than ambient. The chamber shall be capable of maintaining the test specimen at the required temperature and humidity throughout the test. Tests shall be conducted in the same environment as the specimens were conditioned in. When the interested parties agree, it is permitted to undertake impact and compression tests under ambient conditions after hot-wet conditioning procedures.

NOTE The impact and compression properties of fibre-reinforced plastics are affected by moisture absorption.

6 Test apparatus

6.1 General

The test apparatus consists of an impact facility, a specimen support fixture, suitable non-destructive testing equipment, a compression-testing machine, a compression fixture, tools for measurement of the specimen dimensions and a strain measurement system. Details of each of these items are provided in the following subclauses.

6.2 Impact facility

The impact facility shall be fitted with a steel drop-weight indenter with a hemispherical head $(16 \pm 0,1)$ mm in diameter. The impact facility shall be mounted on a rigid base and have a suitable guide mechanism for the drop-weight indenter, as shown in Figure 2. The indenter shall impact the centre of the top surface of the specimen by dropping under gravity with minimal friction effects from the guide rails. A second-strike prohibition mechanism shall be employed to ensure that specimens are only impacted once, i.e. to prevent bouncing of the indenter and therefore multiple strikes. The recommended mass of the indenter is 5 kg to 6 kg and the hardness of the indenter tip shall be between 60 HRC and 62 HRC (Rockwell, diamond cone, 150 kg). The minimum drop height is determined by the mass of the indenter, the specimen thickness and the specified impact energy, as given in 8.3.

NOTE The use of an instrumented impact facility capable of measuring indenter velocity and indentation forces and having a data acquisition system is preferred. ISO 6603-1 and ISO 6603-2 are suggested as references.

6.3 Support fixture for specimen during impact test

The specimen support fixture shall hold the specimen flat against the support frame during impact, holding it down with sufficient, but not excessive, force at its four corners using rubber-tipped toggle clamps. The fixture shall consist of a base 18 mm thick made of steel with a surface which is flat to within 0,1 mm in the region of contact with the specimen. The base-plate shall contain a window (125 ± 1) mm in length and (75 ± 1) mm in width. An example of a suitable support is shown in Figure 3.

The support fixture shall be supported rigidly on a solid base such as the impact facility or the room floor.

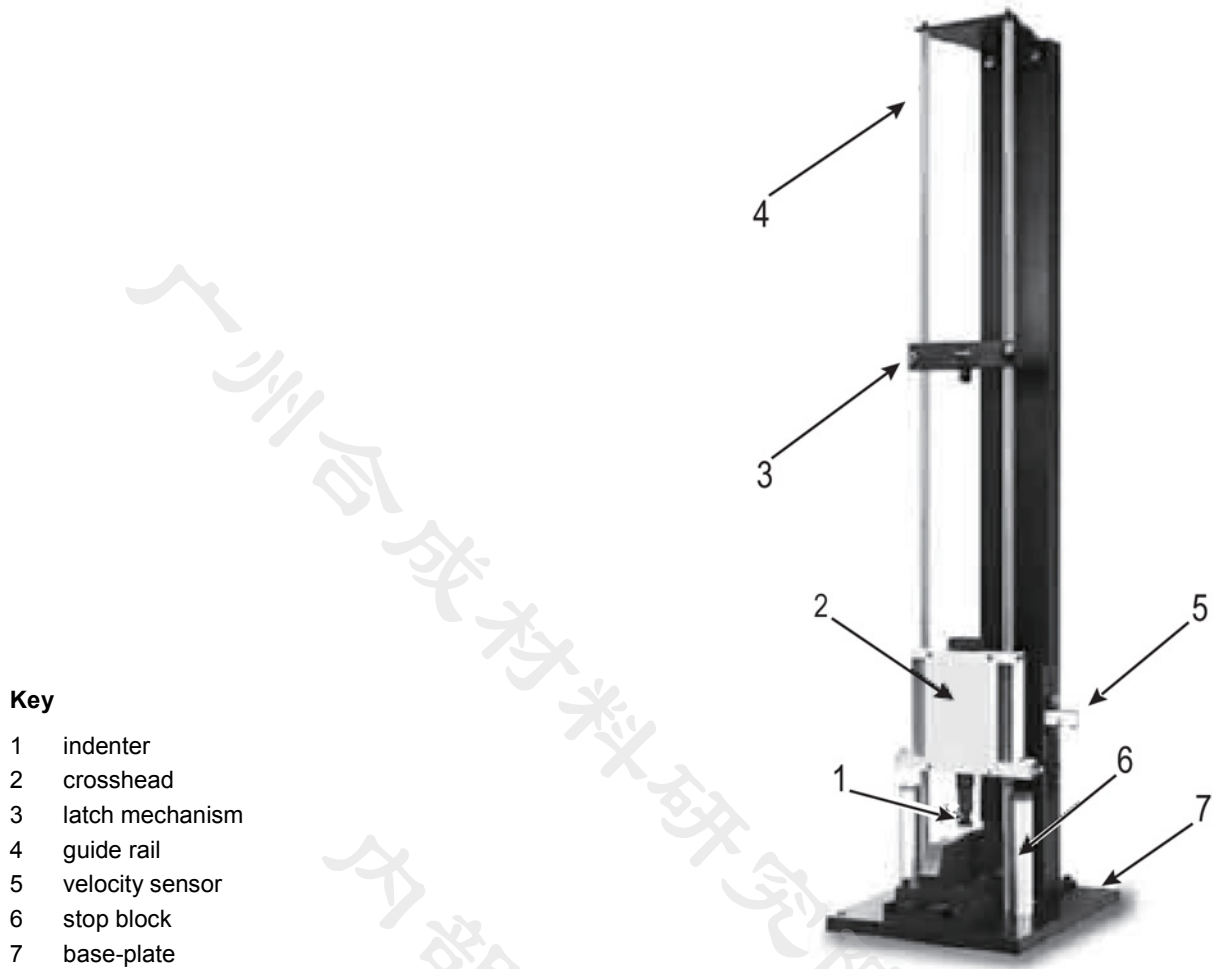

Key

- 1 indenter
- 2 crosshead
- 3 latch mechanism
- 4 guide rail
- 5 velocity sensor
- 6 stop block
- 7 base-plate

Figure 2 — Instrumented drop-weight impact device with double guide rails

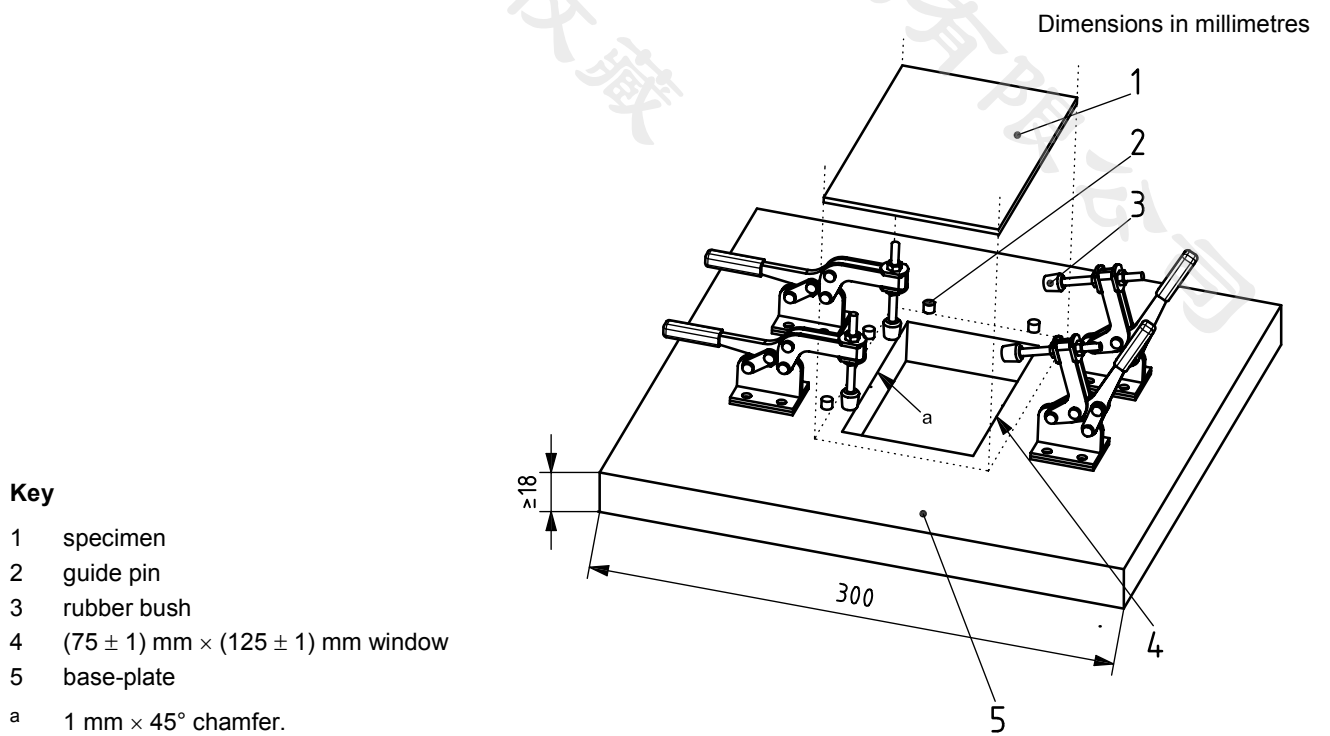

Key

- 1 specimen
- 2 guide pin
- 3 rubber bush
- 4 (75 ± 1) mm × (125 ± 1) mm window
- 5 base-plate
- a 1 mm × 45° chamfer.

Figure 3 — Example of a specimen support fixture

6.4 Non-destructive testing instrument

Non-destructive testing shall be undertaken using a technique capable of detecting delamination damage created by impact between laminae in the specimen. Although the recommended technique is ultrasonic C-scan (using traceable procedures as detailed in Reference [1]), other proven techniques including X-ray radiography with penetrant and pulse thermography may be used for determining delamination extent as well, whereas X-ray radiography with penetrant is usually used for detecting fibre breakage and matrix cracks in laminae. From the image, the edge of the delamination can be identified. Commercially available pulse thermography systems can be used for delamination detection with almost the same reliability as ultrasonic C-scan.

6.5 Compression-testing machine

6.5.1 General

The test machine shall comply with ISO 5893 and meet the specifications given in 6.5.2 and 6.5.3.

6.5.2 Test speed and configuration

The test machine shall be capable of maintaining the required test speed (see 8.6.3). A short loading train and flat end-loading platens shall be used. The test machine shall be mounted with well-aligned, fixed (as opposed to spherical-seat) platens. The platen surfaces shall be parallel to within 0,03 mm across the test fixture top-plate length of 100 mm. If the platens are not sufficiently hardened, or simply to protect the platen surfaces, a hardened plate (with parallel surfaces) can be inserted between each end of the fixture and the corresponding platen. The lower platen should preferably be marked to help centre the test fixture between the platens.

6.5.3 Indication of load

The error in the indicated load shall not exceed ± 1 %.

6.6 Compression-loading fixture

The compression-loading fixture (see Figure 4) shall be designed to provide support to the specimen and to introduce an in-plane compressive load perpendicularly to its upper and lower edges. The support conditions at the four edges of the specimen shall be as follows: the specimen shall be supported in a way which approximates to simple support using knife edges along the longitudinal sides (translational motion of the specimen in the out-of-plane direction prevented, but rotation allowed) and the upper and lower edges shall be clamped in a way which prevents, as far as possible, both translational motion in the out-of-plane direction and rotational motion of the edges of the specimen. The fixture shall be adjustable to accommodate small variations in specimen length, width and thickness. The sliding edges shall be sufficiently short to ensure that a gap is maintained between each lateral angle bracket and the upper platen during the test. An example of a suitable compression-loading fixture is shown in Figure 4. Detailed drawings of each component, including dimensional tolerances, are provided in Annex A. The test fixture may be made of low-carbon steel for ambient-temperature testing. For non-ambient environmental conditions, the recommended fixture material is non-heat-treated ferritic or precipitation-hardened stainless steel (heat treatment for improved durability is acceptable but not required).

Prior to the test, the fixtures shall be checked for conformity with the dimensions specified in Annex A. The position of the lateral angle brackets shall be adjusted such that 0,8 mm to 1,5 mm clearance will be present between each bracket and the longitudinal edge of the test specimen. The fixture shall be placed between the platens and loaded in compression at each end.

NOTE This test is sensitive to the parallelism of the specimen ends as well as to the precise perpendicularity of the various components of the compression-loading fixture. Experience has shown that fixtures may be damaged in use, thus periodic verification of the fixture dimensions and tolerances is important.

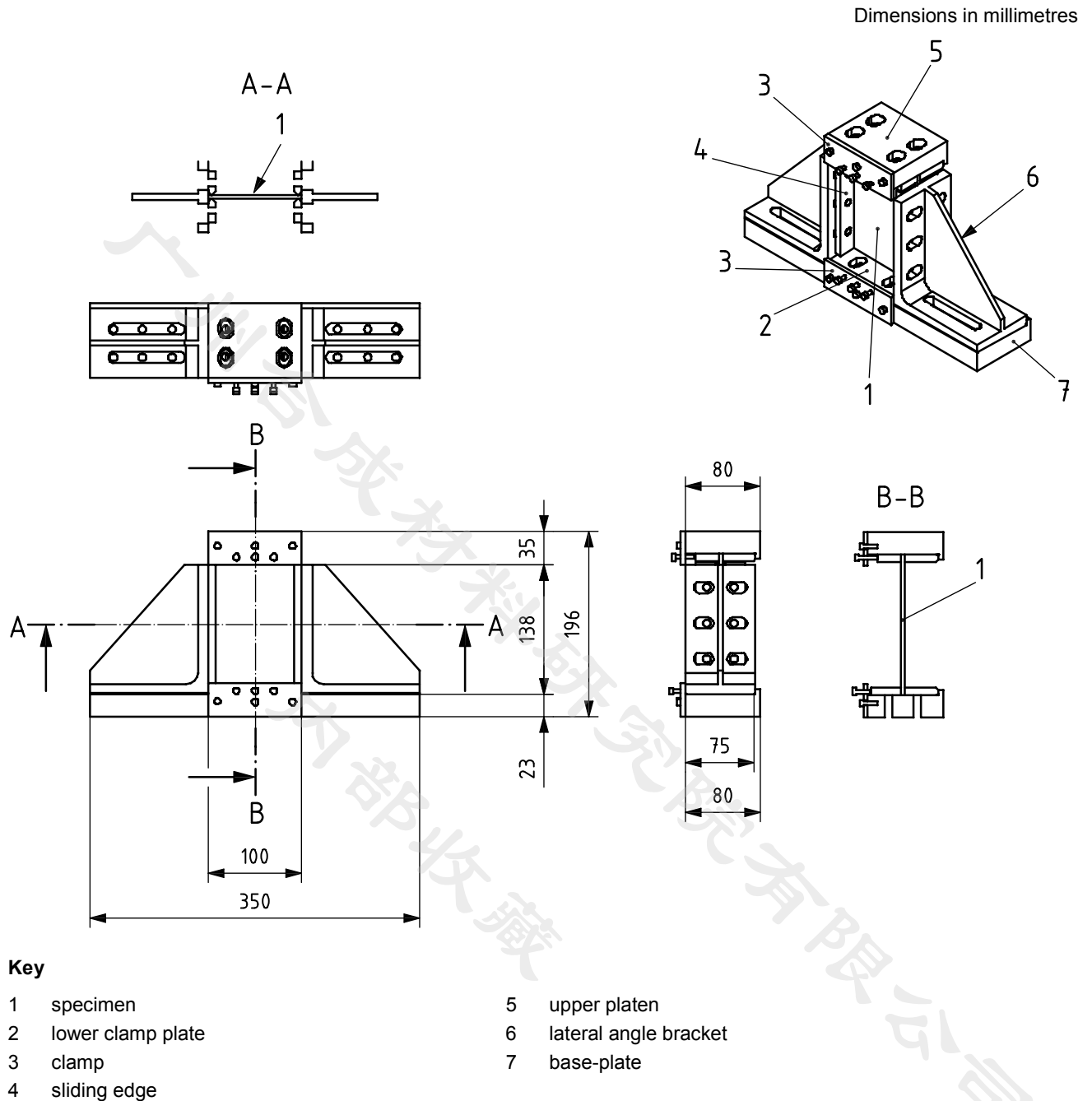

Figure 4 — Example of a compression-loading fixture

6.7 Measuring apparatus

6.7.1 Micrometer

A micrometer, or equivalent, capable of reading to 0,01 mm or better, shall be used to determine the thickness and width of the specimen. The micrometer head shall have faces appropriate to the surface being measured (i.e. flat faces for flat, polished surfaces and hemispherical faces for irregular surfaces).

A micrometer with a suitable attachment may also be used for the measurement of the depth of the dent caused by the indenter on impact, as described in 8.5 (see Figure 5). For such measurements, the micrometer head shall be hemispherical with a diameter of 1,5 mm to 5,0 mm. The length of the attachment shall not be less than 40 mm.

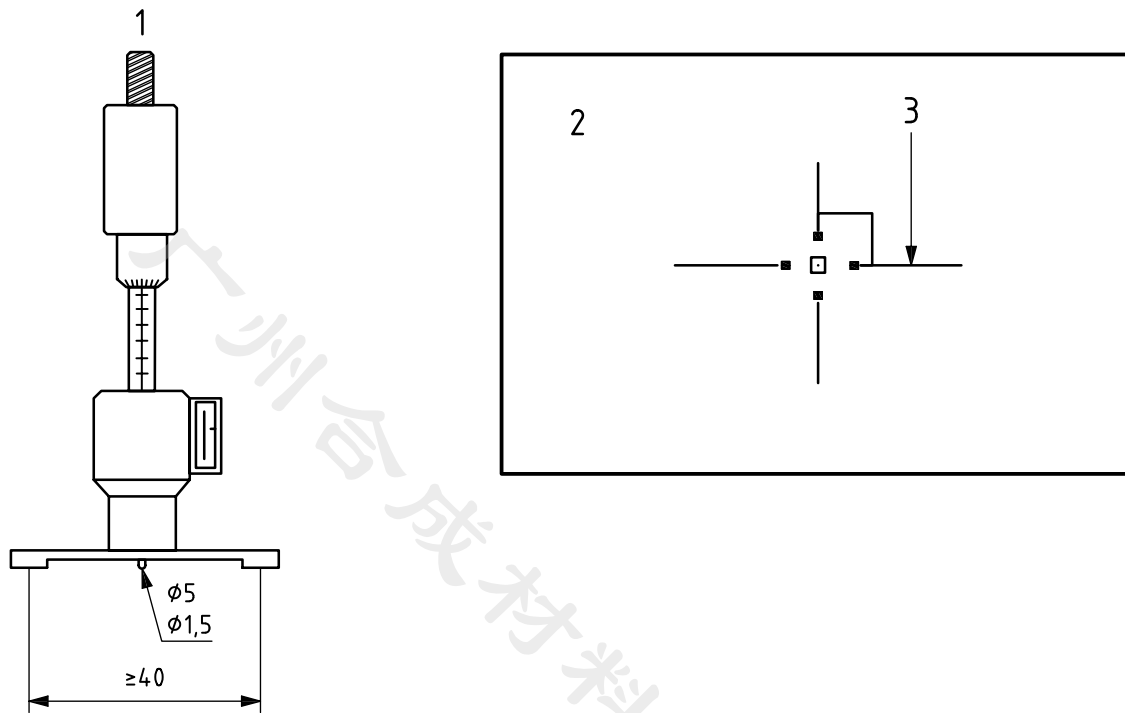

Key

- 1 depth micrometer
- 2 specimen
- 3 depth measured twice (in two directions at right angles to each other)

Figure 5 — Schematic diagram of micrometer with attachment for depth measurement and placement of the attachment on the specimen

6.7.2 Vernier callipers

Vernier callipers, or the equivalent, capable of reading to 0,05 mm or better, shall be used to measure the specimen length and the distances of the strain gauges (6.8) from the edges of the specimen.

6.8 Strain gauges

Longitudinal strain shall be measured during the compression phase by means of strain gauges at two locations (see Figure 6) on each face of the specimen. The sensing element of the strain gauge shall not be more than 3 mm in length. The error in the strain indicated shall not exceed $\pm 1\%$. The gauges, the surface preparation and the bonding agents used shall be chosen to give adequate performance with the material being tested, and suitable strain-recording equipment shall be employed. Strain measurements shall be made for all specimens tested.

7 Specimens

7.1 Dimensions

Each test specimen shall be a flat, rectangular plate ($150 \pm 0,2$) mm in length and ($100 \pm 0,2$) mm in width. A specimen thickness of (5 ± 1) mm is recommended for laminates fabricated from unidirectional and fabric prepreg material. A degree of variation in specimen thickness is permitted, depending on the density per unit surface area of the prepreg fibre and the number of plies in the laminate. The specimen geometry and dimensions are shown in Figure 6, together with the locations of the strain gauges used for monitoring the

strain and degree of bending during compression testing. Note that the direction of edge “A” shall coincide with the 0° fibre direction (see ISO 1268-4:2005, Annex A). The parallelism between edges “B” and “C” shall be better than 0,02 mm and that between the two longitudinal edges “A” better than 0,2 mm. The perpendicularity between edges “A” and each of edges “B” and “C” shall be better than 0,2 mm.

Dimensions in millimetres

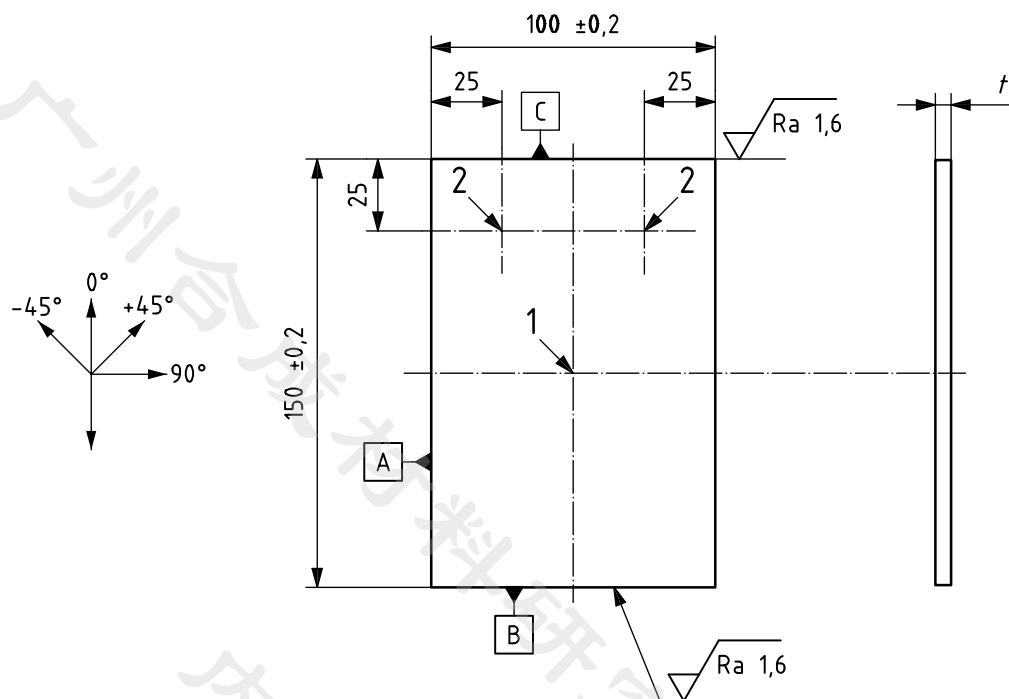

Key

- 1 impact point
- 2 locations of strain gauges (mounted in pairs back to back)

Figure 6 — Specimen geometry and dimensions and strain gauge locations

7.2 Specimen preparation

7.2.1 Specimens shall be machined from a laminated panel fabricated, using an autoclave or hot press, as specified in ISO 1268-4 or as agreed between the interested parties. The size of the panel shall be such that, after removal of a 25 mm strip round the edges, the desired number of specimens can be cut from it. Measure the fibre content, by volume, of each panel in accordance with ISO 14127 or as agreed between the interested parties.

If unidirectional prepreg tape is used as a constituent, a quasi-isotropic $[45/0/-45/90]$ laminate shall be the basic component (see ISO 1268-4:2005, Annex A, for details of the laminate stacking designation system used in this subclause), and shall be repeated n times and symmetrically laminated with respect to the central plane. The panel shall also be balanced in in-plane properties. A stacking sequence slightly different from quasi-isotropic, $[45_i/-45_j/0_k/90_l]_{ms}$, where i , j and k are determined such that the total ply thickness in each of the four major directions exceeds 10 % of the plate thickness, may be used for the specimens.

NOTE If the density per unit surface area of the fibres in the prepreg is 190 g/m^2 , $n = 3$ results in the recommended thickness range. Hence the appropriate laminate is $[45/0/-45/90]_{3s}$ with 24 plies. If the density per unit surface area of the fibres in the prepreg is 145 g/m^2 , the laminate is $[45/0/-45/90]_{4s}$ with 32 plies. If the density per unit surface area of the fibres in the prepreg is 95 g/m^2 , the laminate is $[45/0/-45/90]_{6s}$ with 48 plies.

If fabric prepreg is used as the constituent material, the basic component shall be $[(\pm 45), (0/90)]$ and it shall be repeatedly and symmetrically laminated. As with the tape case above, a stacking sequence of $[(\pm 45)_i, (0/90)_j]_{ms}$ may be used under the same conditions.

7.2.2 Specimens shall be machined from the panel, paying attention not to cause damage at the specimen edges. Cut a margin of 25 mm or more from the panel as fabricated. The machined surfaces shall be smooth and free of notches, scratches, burrs and any other flaws. In order to apply an exact in-plane load without any offset, the upper and lower surfaces "B" and "C" of the specimen shall be machined with sufficient accuracy in terms of roughness and parallelism (see 7.1). Check the rectangularity of the specimen by measuring the lengths of the diagonals.

7.2.3 Because the state of the surface of the specimen can affect the result of the impact, either the top or the bottom surface with respect to the curing shall be identified during the machining procedure to enable the tool surface to be distinguished from the mould surface.

7.3 Number of specimens

The number of specimens tested shall be five or more at any particular impact energy or under any particular set of experimental conditions. Tests which give widely differing results or involve an invalid failure mode shall be disregarded. When determining the number of specimens to be prepared, do not forget to allow for repeat tests. The test result acceptance and re-test criteria are covered in Clause 9.

8 Procedure

8.1 Specimen conditioning

Condition the test specimens as specified in the International Standard for the material being tested. In the absence of this information, select the most appropriate set of conditions from ISO 291, unless otherwise agreed by the interested parties, e.g. when testing at elevated or low temperatures.

8.2 Measurement of specimen dimensions

Measure the specimen thickness, t , to the nearest 0,01 mm at four widely spaced points 25 mm from the edges of the specimen, and record the average thickness. Measure the specimen width, b , to the nearest 0,01 mm at the centreline. Measure the specimen length to the nearest 0,05 mm at the specimen centreline and at two other positions and record the average length.

8.3 Impact test

8.3.1 Position the specimen centrally on the specimen support fixture as shown in Figure 3 and hold it in place by mechanical toggle clamps. Note the face that will be directly contacted by the indenter.

8.3.2 The impact energy shall be 6,7 joules per millimetre thickness [2] or as agreed between the interested parties. Calculate the necessary impact energy, E , in joules, using Equation (1):

$$E = E_c t \quad (1)$$

where

E_c is the specified impact energy per unit thickness, in joules per millimetre thickness, i.e. 6,7 J/mm;

t is the thickness of the test specimen, in millimetres.

8.3.3 Calculate the drop height, h , in metres, necessary to give this impact energy using Equation (2):

$$h = \frac{E}{mg} \quad (2)$$

where

m is the mass of the indenter, in kilograms;

g is the acceleration due to gravity, in metres per second per second, i.e. 9,81 m/s².

If a 5 kg indenter is used, the drop height will be 68,3 cm for a specimen thickness of 5 mm. If a 6 kg indenter is used, the drop height will be 56,9 cm. Because the minimum drop height is defined as 30,0 cm, the heaviest indenter for a specimen thickness of 5 mm is 11,4 kg. If the material being tested is too brittle (i.e. if it breaks on impact) or if it is too tough for impact damage to be caused, select another impact energy.

8.3.4 Impact the specimens using the impact facility described in 6.2. Specimens shall receive only one impact. Second or multiple impacts shall be avoided by using a suitable second-strike prevention device.

8.4 Non-destructive testing (NDT)

Impacted specimens shall be inspected using ultrasonic C-scan or another suitable NDT technique (see 6.4) and typical damage parameters, such as the projected area of delamination, the maximum diameter of delamination and the type of damage shall be determined and recorded. A typical example of a 2D delamination map obtained by C-scan inspection is shown in Figure 7 together with some typical damage patterns.

Users should note that, when the width of the delaminated region width exceeds half the specimen width, there is the possibility of specimen edge effects affecting the result. In such cases, a reduction in impact energy is recommended.

8.5 Inspection of dent in specimens

Visually inspect each specimen on the impacted and the opposite face to ascertain the level of visible damage in terms of the dent size and shape, fibre breakage, ply splitting, etc. After visual inspection, measure the dent depth to the deepest point by means of a depth gauge or a micrometer with a suitable attachment, capable of measuring to the nearest 0,01 mm (see 6.7.1 and Figure 5). The dent depth shall be measured twice in two directions at right angles to each other (see Figure 5) and the results averaged. Relaxation effects occurring after impact may affect the result of the dent depth measurement. Carry out the measurement immediately after impact, therefore. If information on such relaxation effects is required, the recommended time interval between impact and depth measurement is 7 days.

8.6 Compression test

8.6.1 After impact and non-destructive testing, bond four strain gauges to the specimen using a suitable adhesive.

8.6.2 Position the specimen in the compression-loading fixture as shown in Figure 4 such that the machined ends of the specimen are flush with the ends of the two sides of the fixture. This should result in the impact-damaged region of the specimen being positioned centrally in the fixture. Support the specimen using the sliding edges attached to the lateral angle brackets and the clamp plates, and align the specimen by adjusting the sliding edges, making sure that the specimen is held perpendicular to the base-plate of the fixture. Tighten the horizontal bolts in the lower clamp to hold the specimen in place. Tighten the bolts in the clamp plates to ensure lateral support for the specimen. Place the upper platen on top of the specimen and tighten the horizontal bolts in the upper clamp. Tighten the bolts in the sliding edges and in the upper clamp plates to hold the specimen. Check for gaps between the clamp plates and the sliding edges using a feeler gauge and adjust the sliding edges as necessary. Then carefully place the compression-loading fixture between the platens of the compression-testing machine, taking care to align the vertical axis of the fixture with the test direction and the central axis of the machine.

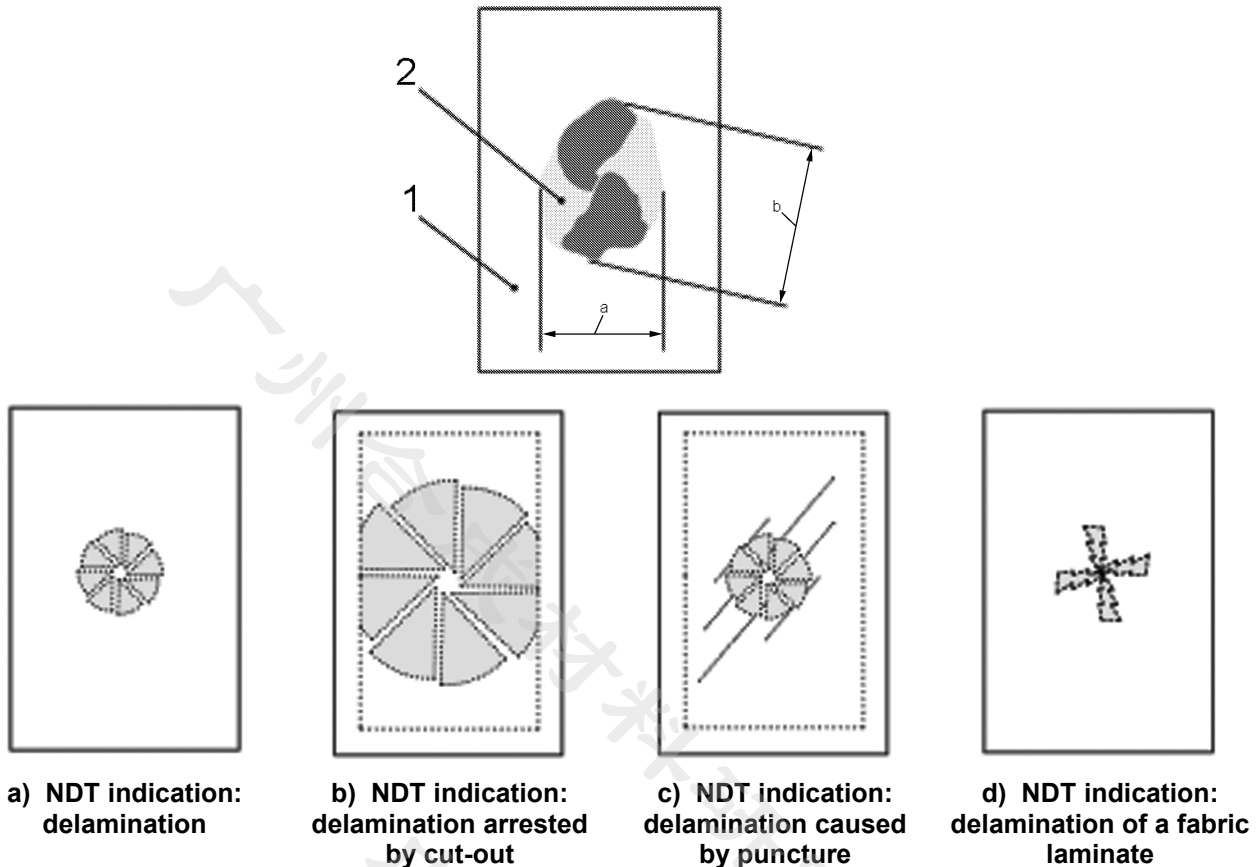

Key

- 1 specimen
- 2 delaminated region
- a Width of delaminated region.
- b Maximum diameter of delaminated region.

Figure 7 — Example of a delamination shape (upper diagram) detected by ultrasonic C-scan and (lower four diagrams) typical damage patterns

8.6.3 Set the test speed (i.e. the crosshead speed) so that failure will be reached within 1 min to 10 min. The recommended test speed is between 0,5 mm/min and 2 mm/min.

8.6.4 Apply a 450 N compressive load to the specimen/compression-loading fixture assembly in order to ensure that all load-bearing surfaces are in contact with each other and to align the platens, if necessary. Then reduce the compressive force to 10 N or less and zero the strain gauges and other instruments.

8.6.5 Apply a compressive load of approximately 10 % of the estimated compressive failure load and record the output from the four strain gauges. Then reduce the compressive force to 10 N or less at the same rate as used for loading. Review the recorded strain gauge data in order to determine the percent bending, B_y , at the maximum applied force for each pair of back-to-back strain gauges as follows (two sets of data will be obtained, one from each pair of strain gauges):

$$B_y = \frac{\varepsilon_1 - \varepsilon_2}{\varepsilon_1 + \varepsilon_2} \times 100 \tag{3}$$

where

- ε_1 is the mean strain indicated by the gauge on one face;
- ε_2 is the mean strain indicated by the gauge on the other face.

8.6.6 Check that the four strain values are all within 10 % of the average of the four mean values and that any offset in the line of application of the compressive load is small. The sign of the calculated percent bending value indicates the direction in which bending has occurred. This information is useful in determining if bending has been produced by a systematic error in test specimen preparation, the apparatus or the procedure rather than by random effects.

If an individual mean strain value is greater than 10 % of the average of all four, unload the specimen and realign it in the compression-loading fixture. Carry out the procedure described in 8.6.5 again and recheck the mean strain values. Note that, if severe delamination has been caused by the impact test, it is sometimes difficult to ensure that the 10 % rule is respected. In such cases, it is permissible, at the test requester's discretion, to continue the test, despite the fact that the 10 % rule has not been respected.

8.6.7 Next, apply a compressive load to the specimen, at the rate required by 8.6.3, until the maximum load has been reached and the load has subsequently dropped to approximately 30 % below the maximum. Unless specimen failure is specifically desired, terminate the test at this point so as to prevent the true failure mode being masked by large-scale distortion and to prevent damage to the compression-loading fixture.

8.6.8 Measure and record the following data:

- a) the load versus strain and load versus crosshead displacement curves, measured on a continuous basis;
- b) the maximum load and the four strain gauge readings at the maximum load;
- c) if any change in specimen compliance or initial ply failure is noted, the load, the displacement (and strain, if available) and the mode of failure at this point;
- d) for each specimen, the failure mode, the location of the failure and the area of the failure region (typical examples of acceptable failure modes are shown in Figure 8 to assist in identifying the mode of failure).

9 Validation

Minor end crushing before final failure at a point along the compressively loaded edges of the specimen can sometimes occur. If the end crushing does not become significant before an acceptable failure occurs in the central region of the specimen, then the test shall be considered valid.

The onset of Euler buckling or excessive bending invalidates the test. For the test results to be considered valid in such cases, the percent bending shall be less than 10 %. Determine the percent bending at the midpoint of the strain range used for calculation of the CAI modulus. The same requirement shall be met at the failure strain for the strength and strain-to-failure data to be considered valid. If possible, a plot of percent bending versus average strain shall be recorded to aid in the determination of the failure mode. A significant fraction of failures (in a sample population) occurring at a location away from the damage location shall be cause to re-examine the means of load introduction into the specimen. Factors to be investigated include the fixture alignment, the gaps between the sliding edges and the specimen, the clamp-fastening torque, the specimen thickness and uneven machining of the specimen ends.

If the test result for a particular specimen deviates significantly from those obtained for the other specimens in a group of specimens tested and the failure mode for this specimen is completely different from that of the others, this result should be treated as an extraordinary one and not reported with the others.

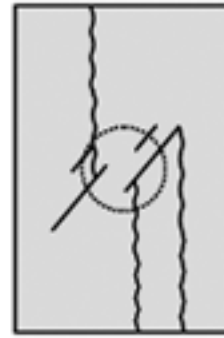
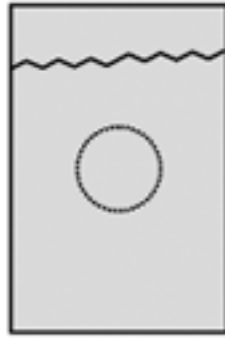
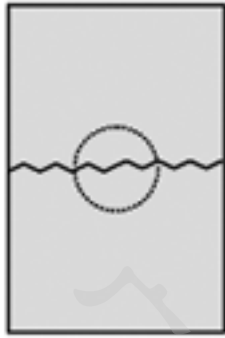

a) Externally visible damage

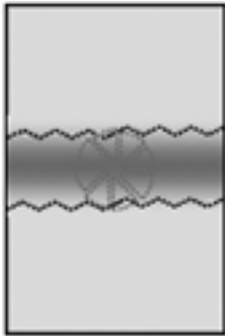

NDT indication: widthwise delamination growing to edge at final failure



NDT indication: end crushing^a

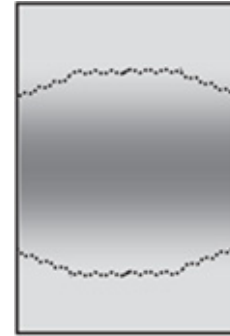

NDT indication: brooming (lengthwise delamination growing to edge at final failure)

b) Internal damage

^a The end-crushing failure mode can occur if the laminate tested is made from a very strong reinforcement and a resin with a low modulus. This mode is only acceptable in the case of such composites. In other cases, end failure alone is not an acceptable failure mode.

Figure 8 — Examples of acceptable failure modes in compression-after-impact tests

10 Calculation of results

10.1 CAI strength

Calculate the CAI strength, σ_{CAI} , expressed in megapascals, using Equation (4):

$$\sigma_{CAI} = \frac{F}{bt} \tag{4}$$

where

- F is the maximum compressive load, expressed in newtons;
- t is the thickness of the test specimen, in millimetres;
- b is the width of the test specimen, in millimetres.

10.2 CAI modulus

Calculate the CAI modulus, E_{CAI} , expressed in gigapascals, using Equation (5):

$$E_{CAI} = \frac{F_2 - F_1}{(\varepsilon_2 - \varepsilon_1)bt} \times 10^{-3} \quad (5)$$

where

ε_1 is the strain value of 0,000 5 (near the lower limit of the linear part of the stress-strain curve);

ε_2 is the strain value of 0,002 5 (near the upper limit of the linear part of the stress-strain curve);

F_1 is the compressive load at strain ε_1 , expressed in newtons;

F_2 is the compressive load at strain ε_2 , expressed in newtons;

t is the thickness of the test specimen, in millimetres;

b is the width of the test specimen, in millimetres.

The strain values are defined as the averages of the four strain gauge readings. Although ε_1 and ε_2 are defined as 0,000 5 and 0,002 5, respectively, other values may be used provided they are close to the lower and upper limits of the linear part of the stress-strain curve.

10.3 Maximum CAI strain

The maximum CAI strain is defined as the average of the four strain gauge readings at the maximum compressive load.

10.4 Rounding the results

The raw data and corresponding average values shall be rounded to three significant digits as specified in ISO 80000-1:—, Annex B, rule A.

10.5 Standard deviation and coefficient of variation

Calculate the standard deviation, σ , and the coefficient of variation, CV, using Equations (6) and (7). They shall be rounded to two significant digits as specified in ISO 80000-1:—, Annex B, rule A.

$$\sigma = \sqrt{\frac{\sum (x - \bar{x})^2}{n - 1}} \quad (6)$$

$$CV = \frac{\sigma}{\bar{x}} \times 100 \quad (7)$$

where

σ is the standard deviation;

CV is the coefficient of variation, expressed as a percentage;

x is an individual data point;

\bar{x} is the average of the data points;

n is the number of data points.

11 Test report

The test report shall include the following information:

- a) the specification and grade of the material tested, the name of the manufacturer, the manufacturer's batch or lot number, the fibre code, the tow or yarn filament count and twist, details of any sizing, the density per unit surface area of the fibre, the type of matrix, the matrix content and the volatile-matter content;
- b) the method of fabrication of the test panel, including the process used, the method of consolidation of the laminate, the degree of cure, the laminate stacking sequence and the fibre content;
- c) the specimen thickness and, if required, the actual (measured) length and width of each specimen, as well as the location from which each specimen was taken in the test panel;
- d) the number of specimens tested;
- e) details of specimen conditioning (temperature, relative humidity and time);
- f) the ambient temperature and relative humidity at the time the test was carried out (if tests were undertaken under special environmental conditions, such as impact at an elevated temperature and compression at ambient, report these conditions);
- g) the type of impact facility used and its configuration (including the diameter of the indenter head, the total mass of the indenter, the nominal impact energy and the drop height used), the type of compression-testing machine used (e.g. screw-driven or hydraulically powered), details of the data acquisition equipment (including the data-sampling rate), the type of non-destructive testing device and method used and the type of strain gauge used;
- h) details of any calibration of the impact facility;
- i) the impact test conditions (impact energy, impact velocity and identification of the specimen surface which was impacted);
- j) details of the damage caused by the impact, including the type of damage, the shape and extent of the damaged region, the average dent depth for each specimen and the average dent depth and coefficient of variation (in percent) for all the specimens tested (if relaxation effects are being studied, also report the time interval between impact and dent depth measurement);
- k) the crosshead speed used in the compression test;
- l) the mode of failure during the compression test, the location of the failure and the area of the failure region;
- m) the CAI strength [the individual results, their average, the standard deviation and the coefficient of variation (in percent)];
- n) (if required) the CAI modulus [the individual results, their average, the standard deviation and the coefficient of variation (in percent)];
- o) the maximum CAI strain [the individual results, their average, the standard deviation and the coefficient of variation (in percent)];
- p) (if required) the load versus strain or load versus crosshead displacement data for each specimen and the load versus percent bending data for each specimen;
- q) the date of the test and the name(s) of the test operator(s);
- r) details of any variations with respect to the method specified, any anomalies noticed during testing and any equipment problems which occurred during testing;
- s) details of any special features.

Annex A
(normative)

Detailed drawings of the components of the compression-loading fixture

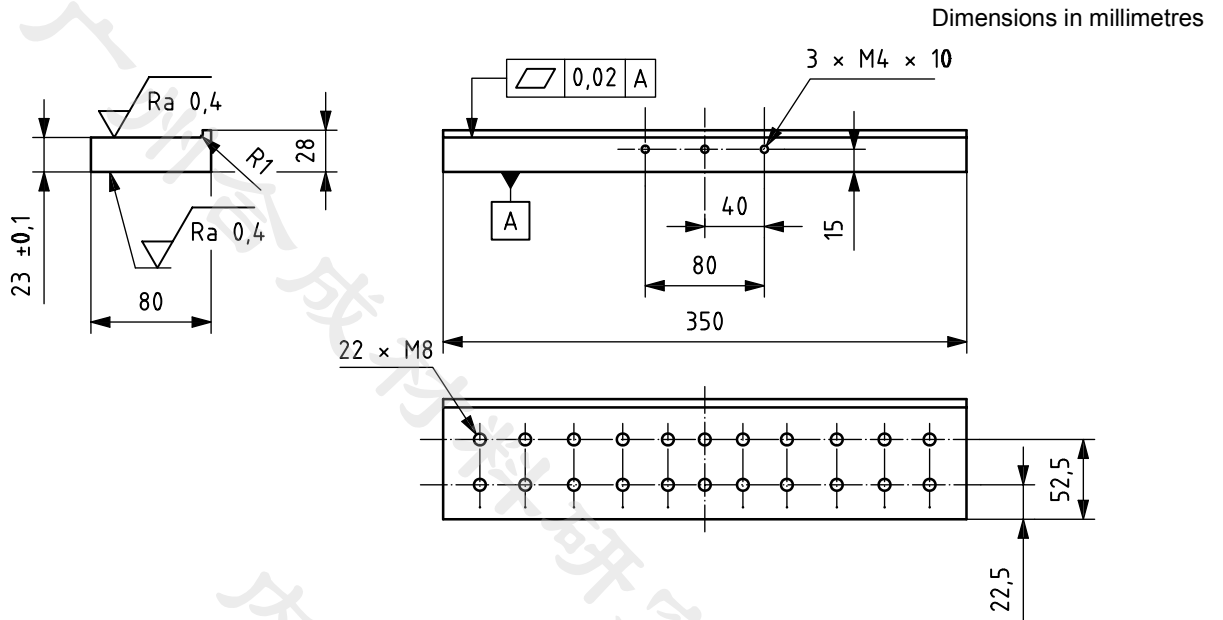

Figure A.1 — Basic dimensions of the base-plate

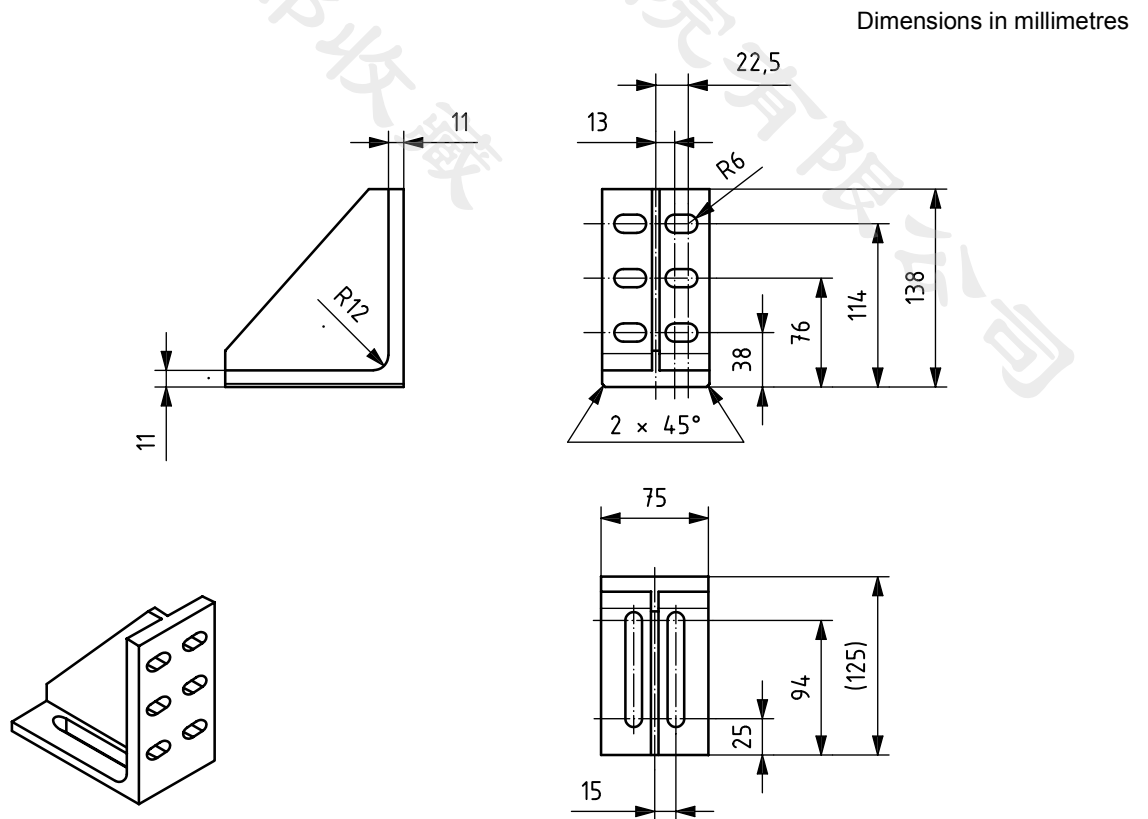

Figure A.2 — Basic dimensions of the lateral angle bracket

Dimensions in millimetres

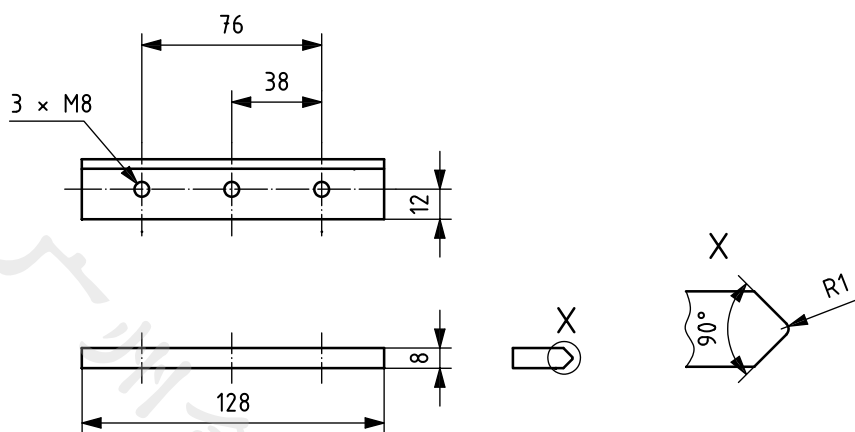

Figure A.3 — Basic dimensions of the sliding edge

Dimensions in millimetres

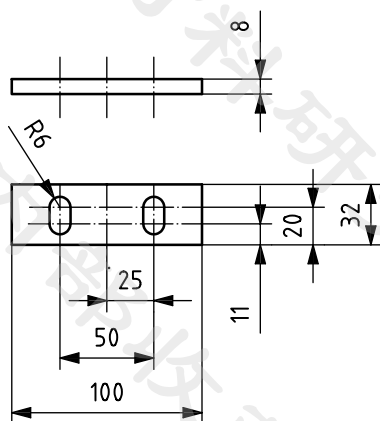

Figure A.4 — Basic dimensions of the lower clamp plate

Bibliography

- [1] EN 1330-4, *Non destructive testing — Terminology — Part 4: Terms used in ultrasonic testing*
- [2] *Results of Research for Standardization of Test and Evaluation Method for New Material For Energy Saving*, MITI Funding Report for FY1992, JHPC 5-2, Mar. 1993 (in Japanese)
- [3] *Results of Research for Standardization of Test and Evaluation Method for New Material For Energy Saving*, MITI Funding Report for FY1993, JHPC 6-2, Mar. 1994 (in Japanese)
- [4] *Standard Tests for Toughened Resin Composites, ST-1: Specification for Compression After Impact Test*, NASA Reference Publication 1092, National Aeronautics and Space Administration, 1982
- [5] *NASA Aircraft Industry Standard Specification for Graphite Fiber Toughened Thermoset Resin Composite Material*, NASA Reference Publication 1142, 1985
- [6] *SACMA Recommended Test Method for Compression After Impact Properties of Oriented Fiber Resin Composite*, Suppliers of Advanced Composite Materials Association (SACMA), SRM 2-88, 1988
- [7] *SACMA Recommended Test Method for Compression After Impact Properties of Oriented Fiber Resin Composite*, Suppliers of Advanced Composite Materials Association (SACMA), SRM 2R-94, 1994
- [8] JIS K 7089, *Testing method for compression after impact properties of carbon fibre reinforced plastics* (in English)
- [9] ASTM D 7136/D 7136M, *Standard Test Method for Measuring the Damage Resistance of a Fiber-Reinforced Polymer Matrix Composite to a Drop-Weight Impact Event*
- [10] ASTM D 7137/D 7137M, *Standard Test Method for Compressive Residual Strength Properties of Damaged Polymer Matrix Composite Plates*
- [11] *Advanced Composite Compression Tests*, Boeing Specification Support Standard BSS 7260, Originally issued in 1982
- [12] *CRAG test methods for the measurement of the engineering properties of fibre reinforced plastics*, Technical Report TR 88012, Royal Aerospace Establishment, UK, February 1988
- [13] ISO 6603-1, *Plastics — Determination of puncture impact behaviour of rigid plastics — Part 1: Non-instrumented impact testing*
- [14] ISO 6603-2, *Plastics — Determination of puncture impact behaviour of rigid plastics — Part 2: Instrumented impact testing*

广州合成材料研究院有限公司
内部收藏

广州合成材料研究院有限公司
内部收藏

ICS 83.120

Price based on 20 pages