

---

---

**Plastics film and sheeting —  
Determination of impact resistance by  
the free-falling dart method —**

Part 2:

**Instrumented puncture test**

*Film et feuille de plastiques — Détermination de la résistance au choc  
par la méthode par chute libre de projectile —*

*Partie 2: Essai avec appareil de perforation*



广州合成材料研究院有限公司  
内部收藏



**COPYRIGHT PROTECTED DOCUMENT**

© ISO 2022

All rights reserved. Unless otherwise specified, or required in the context of its implementation, no part of this publication may be reproduced or utilized otherwise in any form or by any means, electronic or mechanical, including photocopying, or posting on the internet or an intranet, without prior written permission. Permission can be requested from either ISO at the address below or ISO's member body in the country of the requester.

ISO copyright office  
CP 401 • Ch. de Blandonnet 8  
CH-1214 Vernier, Geneva  
Phone: +41 22 749 01 11  
Email: [copyright@iso.org](mailto:copyright@iso.org)  
Website: [www.iso.org](http://www.iso.org)

Published in Switzerland

# Contents

|  | Page      |
|--|-----------|
| <b>Foreword</b> .....                                  | <b>iv</b> |
| <b>Introduction</b> .....                              | <b>v</b>  |
| <b>1 Scope</b> .....                                   | <b>1</b>  |
| <b>2 Normative references</b> .....                    | <b>1</b>  |
| <b>3 Terms and definitions</b> .....                   | <b>1</b>  |
| <b>4 Principle</b> .....                               | <b>4</b>  |
| <b>5 Apparatus</b> .....                               | <b>5</b>  |
| 5.1 General.....                                       | 5         |
| 5.2 Test device.....                                   | 5         |
| 5.2.1 General.....                                     | 5         |
| 5.2.2 Energy carrier.....                              | 6         |
| 5.2.3 Striker.....                                     | 7         |
| 5.2.4 Clamping device.....                             | 7         |
| 5.3 Instrument for measuring force and deflection..... | 9         |
| 5.3.1 General.....                                     | 9         |
| 5.3.2 Force measurement sensor.....                    | 9         |
| 5.3.3 Deflection measurement system.....               | 9         |
| 5.4 Thickness gauge.....                               | 9         |
| <b>6 Test specimens</b> .....                          | <b>9</b>  |
| 6.1 Sampling and preparation of test specimens.....    | 9         |
| 6.2 Number of test specimens.....                      | 10        |
| 6.3 Conditioning of test specimens.....                | 10        |
| <b>7 Procedure</b> .....                               | <b>10</b> |
| 7.1 Test atmosphere.....                               | 10        |
| 7.2 Measuring the thickness.....                       | 10        |
| 7.3 Clamping the test specimen.....                    | 10        |
| 7.4 Impact-penetration test.....                       | 10        |
| <b>8 Calculation and expression of results</b> .....   | <b>11</b> |
| <b>9 Precision</b> .....                               | <b>12</b> |
| <b>10 Test report</b> .....                            | <b>12</b> |
| <b>Annex A (informative) General remarks</b> .....     | <b>14</b> |
| <b>Bibliography</b> .....                              | <b>15</b> |

## Foreword

ISO (the International Organization for Standardization) is a worldwide federation of national standards bodies (ISO member bodies). The work of preparing International Standards is normally carried out through ISO technical committees. Each member body interested in a subject for which a technical committee has been established has the right to be represented on that committee. International organizations, governmental and non-governmental, in liaison with ISO, also take part in the work. ISO collaborates closely with the International Electrotechnical Commission (IEC) on all matters of electrotechnical standardization.

The procedures used to develop this document and those intended for its further maintenance are described in the ISO/IEC Directives, Part 1. In particular, the different approval criteria needed for the different types of ISO documents should be noted. This document was drafted in accordance with the editorial rules of the ISO/IEC Directives, Part 2 (see [www.iso.org/directives](http://www.iso.org/directives)).

Attention is drawn to the possibility that some of the elements of this document may be the subject of patent rights. ISO shall not be held responsible for identifying any or all such patent rights. Details of any patent rights identified during the development of the document will be in the Introduction and/or on the ISO list of patent declarations received (see [www.iso.org/patents](http://www.iso.org/patents)).

Any trade name used in this document is information given for the convenience of users and does not constitute an endorsement.

For an explanation of the voluntary nature of standards, the meaning of ISO specific terms and expressions related to conformity assessment, as well as information about ISO's adherence to the World Trade Organization (WTO) principles in the Technical Barriers to Trade (TBT), see [www.iso.org/iso/foreword.html](http://www.iso.org/iso/foreword.html).

This document was prepared by Technical Committee ISO/TC 61, *Plastics*, Subcommittee SC 11, *Products*.

This second edition cancels and replaces the first edition (ISO 7765-2:1994), which has been technically revised.

The main changes are as follows:

- impact failure definition has been added (3.7);
- the list of clamping devices and techniques has been updated (5.2.4);
- the force measurement (5.3) has been aligned with the ISO 6603-2 method;
- the calculation clause (Clause 8) has been aligned with the ISO 6603-2 method;
- test report requirements (Clause 10) have been improved.

A list of all parts in the ISO 7765 series can be found on the ISO website.

Any feedback or questions on this document should be directed to the user's national standards body. A complete listing of these bodies can be found at [www.iso.org/members.html](http://www.iso.org/members.html).

## Introduction

The impact-penetration test described in the ISO 7765 series is used for the assessment of plastic films and thin sheets (hereinafter referred to as films) under an impact stress applied at right angles to the plane of the film.

ISO 7765-1 can be used if it is sufficient to characterize the impact behaviour of the film by an impact failure energy. This document is used if a force-deformation or a force-time diagram, recorded at practically constant velocity of the striker, is necessary for characterization of the impact behaviour.

[Annex A](#) of is for information only.

广州合成材料研究院有限公司  
内部收藏

# Plastics film and sheeting — Determination of impact resistance by the free-falling dart method —

## Part 2: Instrumented puncture test

### 1 Scope

This document specifies a test method for the determination of puncture impact properties of a plastic film using instruments for measuring force and deflection. It is applicable if a force-deflection or force-time diagram, recorded at nominally constant striker velocity, is required for detailed characterization of the impact behaviour. This test method is also required when a small number of test specimens are available, and the staircase method described in the ISO 7765-1 cannot be applied.

The test method is applicable to films of up to 1 mm thickness and makes it possible to compare impact-penetration forces, biaxial deformabilities and energy-absorption capacities of films. Also, the transition region between brittle and tough behaviour of the film under the conditions of testing can be determined by varying the temperature or the penetration velocity or the relative humidity<sup>[1]</sup>.

### 2 Normative references

The following documents are referred to in the text in such a way that some or all of their content constitutes requirements of this document. For dated references, only the edition cited applies. For undated references, the latest edition of the referenced document (including any amendments) applies.

ISO 291, *Plastics — Standard atmospheres for conditioning and testing*

ISO 4593, *Plastics — Film and sheeting — Determination of thickness by mechanical scanning*

### 3 Terms and definitions

For the purposes of this document, the following terms and definitions apply.

ISO and IEC maintain terminology databases for use in standardization at the following addresses:

— ISO Online browsing platform: available at <https://www.iso.org/obp>

— IEC Electropedia: available at <https://www.electropedia.org/>

#### 3.1 peak force

$F_M$

maximum force exerted by the striker in the direction of impact during the test

Note 1 to entry: See [Figures 1](#) to [3](#).

### 3.2 deformation at peak force

$s_M$   
deformation in the direction of impact at the centre of the test specimen corresponding to the *peak force* (3.1)

Note 1 to entry: For materials exhibiting a peak-force plateau, the deformation is taken at the centre of the plateau (see [Figure 1](#)).

### 3.3 energy to peak force

$W_M$   
area under the force-deformation curve bounded by the origin, the peak force and the *deformation at peak force* (3.2)

Note 1 to entry: See [Figures 1](#) to [3](#).

### 3.4 total penetration energy

$W_T$   
area under the force-deformation curve bounded by the origin, the *peak force* (3.1) and the *deformation at peak force* (3.2)

Note 1 to entry: See [Figures 1](#) to [3](#).

Note 2 to entry: If the force-deformation diagram as measured during the test is influenced strongly by dynamic resonance effects, a mean curve may be used to obtain the values of the parameters defined in [3.1](#) to [3.4](#). This, however, is seldom the case when plastic film is tested

Note 3 to entry: In contrast to the instrumented puncture test applied to test specimens made of brittle plastic (see ISO 6603-2), the force-deformation diagram of this test applied to film and sheeting frequently shows a clear point of first failure (failure point) indicated by a sharp drop in the force. If this is the case, and if the interested parties agree to use this point as a characteristic criterion, the following additional definitions may be used.

### 3.5 failure force

$F_F$   
force exerted by the striker in the direction of impact, measured at the failure point

Note 1 to entry: See [Figures 1](#) and [2](#).

### 3.6 failure deformation

$s_F$   
deformation in the direction of impact at the centre of the test specimen, measured at the failure, point

Note 1 to entry: See [Figures 1](#) and [2](#).

#### 3.6.1 failure energy

$W_F$   
area under the force deformation curve bounded by the origin, the *failure force* (3.5) and the *failure deformation* (3.6)

Note 1 to entry: See [Figures 1](#) and [2](#).

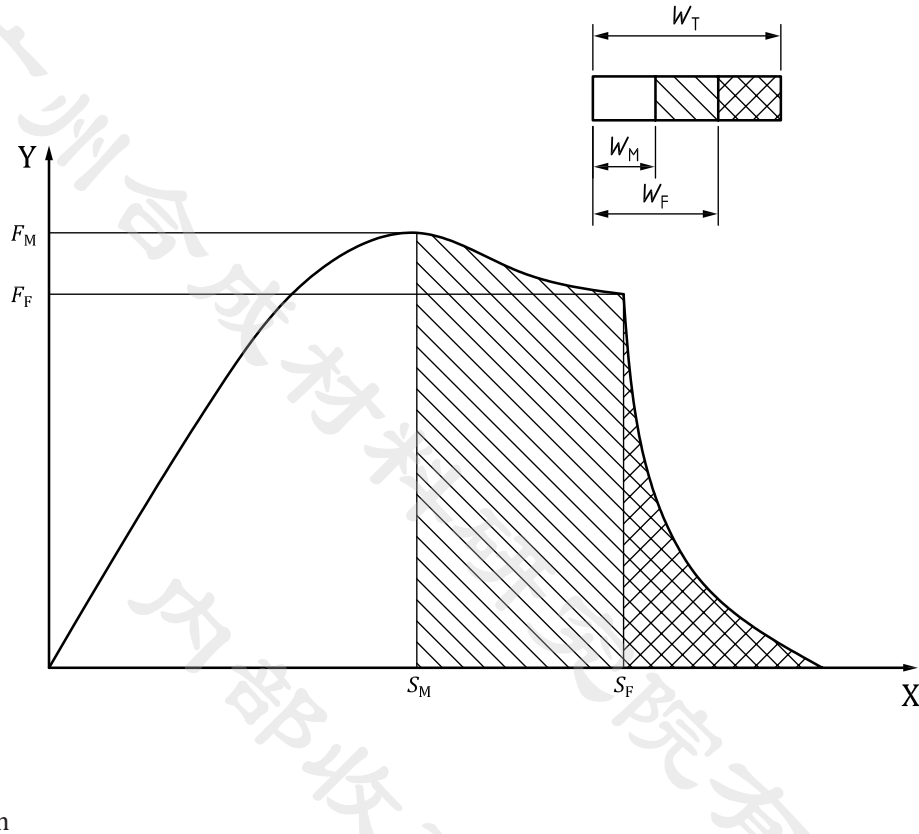
Note 2 to entry: When comparing films of slightly different thicknesses, it is advisable to relate  $F_M$ ,  $F_F$ ,  $W_M$  and  $W_F$  to the thickness  $d$  of the specimen. Though the normalized values  $F_M/d$ ,  $F_F/d$ ,  $W_M/d$  and  $W_F/d$  do not allow a physically exact comparison between film specimens of different materials, the thickness dependence of these normalized values is negligible for similar materials (those with the same amount of crystallinity and the same orientation) provided the thicknesses do not differ by more than a factor of 1,5.

## 3.7

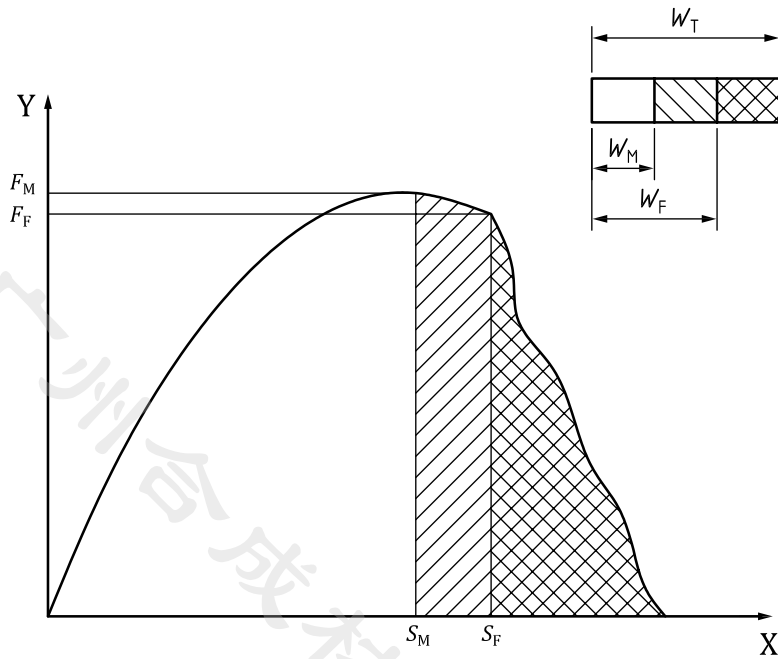
**impact failure**

mechanical behaviour of the material under test which may be either one of the following types:

- a) ductile. If a clear failure point is available and parts agree, the ductile behaviour can be described in terms of “Very tough” (see [Figure 1](#) as example) and “Tough” (see [Figure 2](#) as example)
- b) brittle

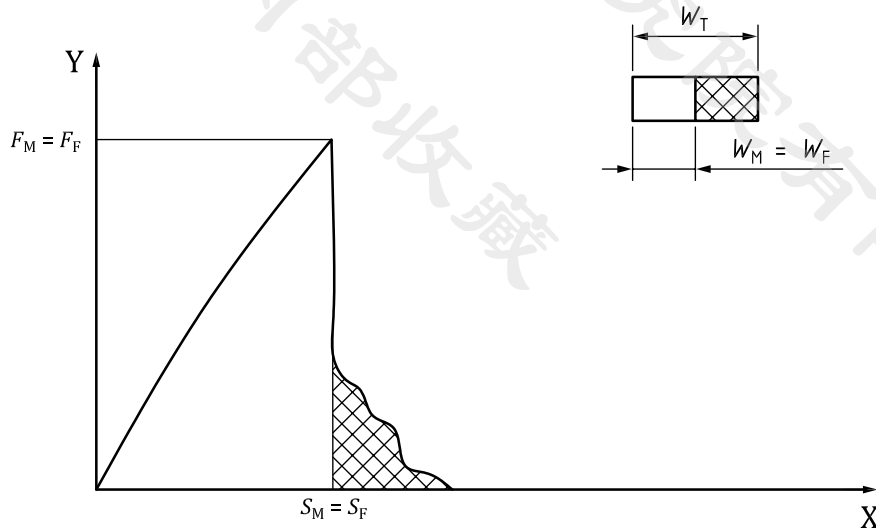


**Figure 1 — Force-deformation diagram for very tough materials (schematic)**



**Key**  
 Y force  
 X deformation

**Figure 2 — Force-deformation diagram for tough materials (schematic)**



**Key**  
 Y force  
 X deformation

**Figure 3 — Force-deformation diagram for brittle materials (schematic)**

## 4 Principle

The test specimen is penetrated normal to its plane by a striker at a nominally uniform velocity. The resulting force-deformation or force-time diagram is electronically recorded. The test specimen is firmly clamped during the test.

The force-deformation diagram obtained in these tests shows several features of the material's behaviour under impact. For example, the fracture may be “brittle”, “ductile” – “tough” or “very tough” – or characterized by initial damage or by crack initiation and propagation. In addition, dynamic effects may be present, such as load-cell/indenter resonance, specimen resonance and initial contact/inertia peaks (see [Figures 1 to 3](#)).

In all cases, care shall be exercised in analysing these features because the operative mechanism and the trains of inference are not yet fully established, and are the subject of continuing research.

The test results are comparable only if the conditions for preparation of specimens, their thickness and surfaces, and the test conditions are identical. Comprehensive evaluation of the reaction to impact stress requires that the determinations are made as functions of deformation rate and temperature for different material variables, such as crystallinity and moisture content.

## 5 Apparatus

### 5.1 General

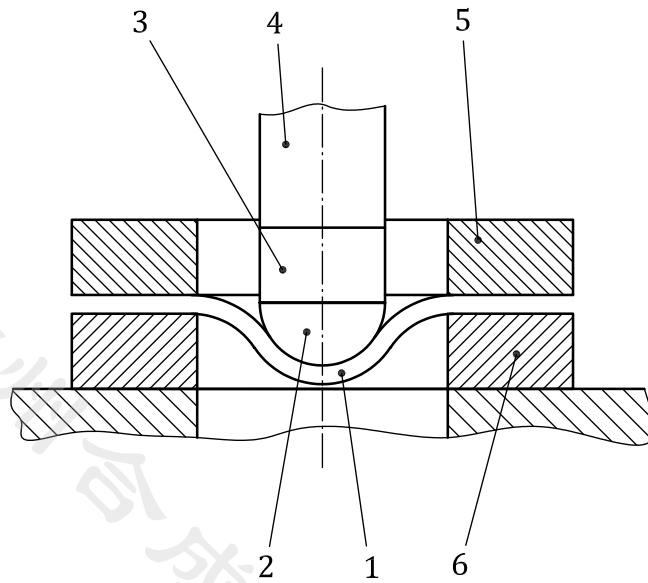
The apparatus consists of a mechanical test device for applying the test force, instruments for measuring the force and the deformation produced, and a thickness gauge.

### 5.2 Test device

#### 5.2.1 General

The essential components of the test device are the energy carrier (normally a falling mass, but a pneumatically, hydraulically or spring-driven mass or a pendulum impact-testing device may also be used), the striker, and the clamping device consisting of the test specimen support and the clamping ring (see [Figures 4 and 5](#)).

The apparatus shall permit the test specimen to be punctured at the centre at a nominally constant velocity, perpendicular to the specimen surface. The force exerted on the test specimen in the direction of impact and the deformation of the specimen in the direction of impact shall be measurable or derivable (see [Figure 4](#)). Equipment suitable for this are falling dart machines, pendulums long enough for the penetration path to be regarded as approximately straight, or high-speed tensile-testing machines with suitable attachments.



**Key**

- 1 test specimen
- 2 hemispherical striker, diameter  $D_1$
- 3 load cell (preferred position)
- 4 shaft
- 5 clamping ring
- 6 test specimen support, inside diameter  $D_2$

**Figure 4 — Test apparatus (schematic)**

**5.2.2 Energy carrier**

The impact energy (e.g. drop energy) available shall be large in comparison to the penetration energy absorbed  $W_T$ . This is because the influence of the test velocity (over the range of velocities used in the test) on the viscoelastic behaviour of plastics is relatively small; a decrease in the velocity of the striker of 20 % is acceptable.

This energy requirement is met by falling-dart machines if [Formula \(1\)](#) is met:

$$m \geq 3 \cdot W_T / g \cdot H_0 \tag{1}$$

where

- $m$  is the falling mass, in kilograms;
- $g$  is the acceleration due to gravity (9,81 m/s<sup>2</sup>);
- $H_0$  is the height of fall, in metres;
- $W_T$  is the total penetration energy, in joules.

The falling-dart system used shall be capable of holding and releasing a weighted striker so that the striker falls constrained by a guide or guide(s). The fall shall be largely without friction or losses through windage. Any friction shall be taken into account in the calculations.

**NOTE** In most cases, a weighted striker with a total mass  $m$  of 10 kg is sufficient.

For all inertial-mass-type energy carriers the impact velocity shall be measured by velocity-measuring sensors placed close to the point of impact, to eliminate errors due to friction between the dart and the guides and to air resistance.

With hydraulically driven high-speed tensile-testing machines, any deviation of the velocity during impact shall be proved, e.g. by plotting the deformation-time curves and checking their slope.

### 5.2.3 Striker

The preferred striker has a polished, hardened, hemispherical striking surface with a diameter  $D_1 = 20 \text{ mm} \pm 0,2 \text{ mm}$ . Alternatively, a striking surface of  $10 \text{ mm} \pm 0,1 \text{ mm}$  diameter may be used. The striker shall be constructed of steel.

The load cell on the striker shall be mounted as close as possible to the tip to minimize the effect of extraneous forces. An example is shown in [Figure 4](#).

The head of the striker may be powdered with talcum or lubricated with oil to reduce friction, provided that the interested parties agree on this procedure and use identical material. In some cases, this can reduce the statistical scatter of the results. It should be borne in mind, however, that lubricating the striker may influence the test results considerably.

### 5.2.4 Clamping device

The test-specimen clamping device shall have an inside diameter  $D_2$  of  $40 \text{ mm} \pm 2 \text{ mm}$ . The clamping device shall be constructed in such a way that the circular specimen can be clamped flat and held securely during the test. The holding technique employed on the specimen shall not interfere with the radius edge of the clamp assembly. The edges of the unsupported region shall be rounded to a radius of  $1,0 \pm 0,5 \text{ mm}$ . The holding technique employed on the specimen shall not interfere with the radius edge of the clamp assembly.

Specimens should be held taut but not stretched, to avoid any radial pre-stretching of the specimen greater than 0,01 %.

The following techniques have been successfully employed for different types of plastic films<sup>[2]</sup>.

- Parallel rigid plates clamped together with enough force (mechanically, pneumatically or hydraulically) to prevent slippage of the specimen during impact. Placing a ring of fine emery paper on the specimen support has been found to be useful;
- Rubber-like gaskets or O-rings affixed to the rigid plates to provide cushioning or gripping of the specimen when clamping force is applied;
- Removable assemblies, consisting of two concentric rings (one slightly larger than the other, similar to an embroidery hoop) that, when assembled and clamped between two rigid plates, succeed in pulling the specimen taut over the specified unsupported region prior to testing.
- Corrugated rigid plates clamped together with enough force (mechanically, pneumatically or hydraulically) to prevent slippage of the specimen during impact.

An example is provided in [Figure 5](#) as suggested clamping-device design.



### 5.3 Instrument for measuring force and deflection

#### 5.3.1 General

To measure the force exerted on the specimen, the striker may be equipped with strain gauges or a piezoelectric transducer, which may be placed close to the striking edge (see [Figure 4](#)). Any other suitable method of force measurement is acceptable.

#### 5.3.2 Force measurement sensor

The force-measurement system shall be able to measure forces with an accuracy of  $\pm 2\%$  of the maximum impact force, which has occurred during the test.

The force-measurement system shall be calibrated as set up ready for use. Calibration may be performed statically (e.g. by imposing known loads on the striker). The range for which the force measurement system works within an accuracy of  $\pm 2\%$  of the reading shall be indicated.

The natural frequency,  $f_n$ , of the force-measurement system in the test configuration shall be greater than three times the resonance frequency,  $f_s$ , of the specimen after impact.

NOTE For plastics films test specimens, the resonance frequency,  $f_s$ , is of the order of few kHz, typically 2 kHz to 10 kHz. A natural frequency,  $f_n$ , of 30 kHz for the force-measurement system is generally acceptable for plastics. The greater the difference between  $f_n$  and  $f_s$ , the easier the detection of failure initiation and growth.

The upper bandwidth limit of the amplifier train (direct-current or carrier-frequency amplifier) shall be selected so that it does not cut across the frequency response of the test device.

In order to monitor the force acquisition adequately, the sampling frequency of the force-measurement system (transient recorder) shall be at least 100 Hz.

If post-filtering is used, the type of filter and its basic characteristics shall be given in the test report.

#### 5.3.3 Deflection measurement system

The deformation of the specimen in the direction of penetration can be determined directly with an electronic transducer, thus yielding a force-deformation curve. The instrument for measuring deformation shall be capable of measuring the deformation to within 5 % of its maximum value. If deflections are measured directly, the same sampling frequencies shall be used as for the impact force. The resolution of the time measurement and that of the distance measurement shall be matched.

It is also possible to record a force-time curve and calculate the deformation in accordance with [Clause 8](#).

### 5.4 Thickness gauge

The instrument for measuring the thickness of the specimen shall fulfil the requirements of ISO 4593. It shall be capable of measuring the thickness  $d$  of the specimen to within 1  $\mu\text{m}$ .

## 6 Test specimens

### 6.1 Sampling and preparation of test specimens

Sampling shall be in accordance with the instructions on the relevant product standard. If no such instructions are given, specimens should preferably be taken from film sheeting or from a piece of the film to be tested. The specimens shall be 80 mm  $\pm$  2 mm in diameter. The cut edges need not be of any particular quality. They shall be as uniform as possible over the whole of the width and taken at right angles to the machine direction of the film. Non-homogeneous edge strips of film rolls shall not be used. If a fairly large number of specimens is required in order to determine the temperature dependence of the measured values, the specimens for the entire test series shall be mixed before testing.

For films having thicknesses greater than 1 mm, ISO 6603-2 should be used.

## 6.2 Number of test specimens

A minimum of five test specimens shall be tested (in the case of arbitration, 20 specimens are required). If the dependence of the measured values on temperature, relative humidity or other parameters is to be determined, five specimens per measurement point are generally sufficient, even in the case of arbitration. The number of test specimens required is doubled if the test result depends on the side from which the film is penetrated.

## 6.3 Conditioning of test specimens

The test specimens shall be conditioned as required by the specifications for the material concerned or as agreed upon by the interested parties. Otherwise, select the most appropriate set of conditions from ISO 291.

# 7 Procedure

## 7.1 Test atmosphere

The test shall be carried out in one of the standard atmospheres specified in ISO 291. If measurements are to be made at different temperatures or relative humidities, the test specimens shall be maintained under each set of test conditions until the results show no further change at that particular temperature or humidity. This conditioning time decreases at higher test temperatures.

## 7.2 Measuring the thickness

Determine the thickness,  $d$ , of each specimen in accordance with ISO 4593 to the nearest 1  $\mu\text{m}$ , taking the average of three measurements at equidistant points on the circumference of a circle of radius 5 mm located at the centre of the specimen.

## 7.3 Clamping the test specimen

The specimen shall be clamped flat. The stress caused by clamping shall not result in an elongation (pre-stretch) of more than 0,01 % in the radial direction (see [5.2.4](#)).

NOTE The pre-stretch can be determined by means of a measuring microscope. The usual clamping device, however, always fulfils the above condition.

## 7.4 Impact-penetration test

The impact-penetration test is conducted with an impact velocity of  $4,4 \text{ m/s} \pm 0,2 \text{ m/s}$ , corresponding to a height of fall  $H_0$  of  $1,0 \text{ m} \pm 0,1 \text{ m}$ . During the test, the speed shall not change by more than 20 % of its value on striking the specimen (see the conditions for the falling mass in [5.2.2](#)).

During the test, the force-deformation diagram or force-time curve shall be recorded. The values of the parameters defined in [Clause 4](#) shall be taken from the curve or read from the recording instrument, such as a transient recorder. If a satisfactory deformation curve cannot be obtained because of resonance effects, then the impact velocity shall be reduced to 1 m/s.

NOTE Although the impact velocity of 4,4 m/s for testing of plastic films, even those made of relatively brittle materials, is normally not too high, the velocity can be reduced if the interested parties agree.

If there is any reason to believe that the results will depend upon which side of the test specimen faces the striker, both sides shall be tested separately (see also [6.2](#)).

## 8 Calculation and expression of results

For routine characterization purposes, the peak of the force-deformation curve shall be used to determine the test results. If it is clear from the force deformation curve and/or other information that crack initiation has occurred in the test specimen, the corresponding point (failure point) on the force deformation curve can also be used to determine the test results.

If the test measurements are in the form of a force deformation curve, the force and deformation at the characterization point can be read directly from the curve. The corresponding energy values are determined by measuring the area under the force-deflection curve, using a planimeter, computer analysis or other suitable means.

Should results be in the form of a force-time curve and the deformation  $s$  of the test specimen may not directly be measured by a displacement measuring system, it shall be calculated from the force-time trace using [Formula \(2\)](#):

$$s(t) = v_0 \cdot t - \frac{1}{m} \cdot \int_0^t \left[ \int_0^{t_1} F(t) \cdot dt_1 \right] dt + \frac{1}{2} g t^2 \quad (2)$$

where

$s(t)$  is the deformation, in metres;

$v_0$  is the impact velocity (see [7.4](#)), in metres per second;

$m$  is the falling mass (see [5.2.2](#)), in kilograms;

$F(t)$  is the force measured at any time after the impact, expressed in newtons;

$g$  is the acceleration due to gravity (9,81 m/s<sup>2</sup>).

Since the last term of the [Formula \(2\)](#) is only valid for an energy carrier moving vertically, its relative contribution increases with decreasing impact velocity (drop height of the striker).

Once the forces and deflections are known for the same times,  $t$ , after impact, calculate the energy  $W_j$ , in joules, expended up to specific deflections by determining the area under the force-deflection curve, i.e. by integrating in accordance with the following [Formula \(3\)](#) (see NOTE):

$$W_j = \int_0^{s_j} F(s) \cdot ds \quad (3)$$

where

$W_j$  is the energy, in joules;

$j$  denotes one of the following points on the force-deflection curve:

maximum (M)

total (T)

failure (F)

$s$  is the deformation, in metres;

$F(s)$  is the force at the deformation  $s$ , expressed in newtons.

**NOTE** In the case of horizontally impacting frictionless energy carriers, the energy can be calculated without measuring the deflection  $s(t)$  by using the following formulae:

$$W_j = W_{ja} \cdot (1 - W_{ja} / 4E) \text{ and}$$

$$W_{ja} = v_0 \int_0^{t_j} F(t) \cdot dt$$

where

$W_j$  is the energy, in joules;

$W_{ja}$  is the approximate value of the energy, calculated assuming a constant velocity  $v_0$ , in joules;

$v_0$  is the impact velocity (see 7.4), in metres per second;

$E$  is the energy of the carrier just before the impact, expressed in joules;

$F(t)$  is the force measured at any time after the impact, expressed in newtons.

The second term inside the brackets is less than 5 % if the ratio  $W/E$  of the measured energy to the energy of the energy carrier at impact is less than 0,2.

## 9 Precision

The precision of this test method is not known because interlaboratory data are not available at the date of publication.

## 10 Test report

The test report shall include the following information:

- a) a reference to this document, i.e. ISO 7765-2:2022;
- b) the type, identification mark, origin and date of receipt of the material tested, plus any other pertinent data concerning the material;
- c) the date of measurement;
- d) the method of sampling and preparation of the test specimens;
- e) the average value of the measured thickness  $d$  of each test specimen;
- f) the test conditions and the conditioning procedure used;
- g) details of the way in which the test specimens were clamped;
- h) the diameter  $D_1$  of the striker and the nature of the striker surface;
- i) the number of test specimens used;
- j) the agreed point of failure, if used;
- k) the arithmetic mean, standard deviation and coefficient of variation of the
  - peak force  $F_M$ , in newtons,
  - deformation at peak force  $s_M$ , in metres,
  - energy to peak force  $W_M$ , in joules,
  - total penetration energy  $W_T$ , in joules,

and optionally the

- failure force  $F_F$ , in newtons,
- failure deformation  $s_F$ , in metres,
- failure energy  $W_F$ , in joules;

Report all calculated mean values to two significant figures.

- l) the impact failure criterion that was agreed upon, if different from that given in [3.7](#);
- m) the force-deformation curve  $F(s)$  or force-time curve  $F(t)$ ;
- n) the natural frequency  $f_n$  of the force-measurement device;
- o) the type and essential characteristics of post-test filtering, if used;
- p) the appearance of the test specimens after the test (possibly with a representative test specimen as an illustrative example);
- q) the test velocity  $v_0$ , if not 4,4 m/s;
- r) if a lubricant was used, the lubricant type, grade, quality and manufacturer.

## Annex A (informative)

### General remarks

In the testing of plastics, tough/brittle transitions are frequently encountered when the test temperature is lowered in stages from high values. At such transitions, the failure energy, for example, rises from a lower to a higher level. These transitions are caused by molecular relaxation processes which become effective only above a certain temperature and which increase the absorption of the impact energy.

Penetration time plays a role similar to that of temperature. If the penetration time is shortened, the transition temperature is shifted to higher temperatures. The relationship between time and temperature is determined by the temperature dependence of molecular relaxation times, which is approximated by the Arrhenius formula [see [Formula \(A.1\)](#)]:

$$\tau = \tau_0 \cdot \exp(E / kT) \quad (\text{A.1})$$

where

- $\tau$  is the relaxation time or penetration time;
- $T$  is the thermodynamic temperature or position of the tough/brittle transition on the temperature scale;
- $E$  is the activation energy.

If the test temperature is in a transition region, a wide scatter of results is frequently observed because the rupture of some specimens is brittle and the rupture of others is tough. In high-density polyethylene, for example, such a transition region lies in the temperature range between  $-105\text{ °C}$  and  $-140\text{ °C}$ , depending on the relative molecular mass and degree of crystallinity.

The tough/brittle transition can be recognized in the puncture test by the appearance of the damaged specimens, which reveals whether rupture occurred with or without deformation. The two types of rupture behaviour can also be distinguished by means of the force-deformation diagram.

For tough/brittle plastics, the performance and evaluation of impact tests are subject to certain limitations, since the test specimens of a single test series shall be assigned to two different parent populations, namely one exhibiting brittle-material behaviour and one exhibiting tough-material behaviour. In such cases, the means and variances are not statistically defined over the entire range of measurements. Nevertheless, it is helpful to employ the mean and standard deviation calculated from the individual measurements to characterize the behaviour of the material.

Where there is a sufficient number of measurements for both parent populations, the characteristic quantities can be calculated separately for the brittle and the tough specimens. If necessary, the choice of assigning measurements to one of the two parent populations should be decided by use of the statistical procedure normally employed for this purpose.

## Bibliography

- [1] GRIMMINGER H., A theory of the interaction typical for the instrumented puncture test by a drop mass. *Z. Werkstofftechn.* 1987, **18** pp. 218–224
- [2] ASTM D7192, *Standard Test Method for High Speed Puncture Properties of Plastic Films Using Load and Displacement Sensors*
- [3] ISO 6603-2, *Plastics — Determination of puncture impact behaviour of rigid plastics — Part 2: Instrumented impact testing*
- [4] ISO 7765-1, *Plastics film and sheeting — Determination of impact resistance by the free-falling dart method — Part 1: Staircase methods*

广州合成材料研究院有限公司  
内部收藏